



Faculty of Engineering

MEP382: Design of Applied Measurement Systems

Lecture 14:

555 Timers

555 TIMER IC HISTORY

- The 555 timer IC was first introduced around 1971 by the Signetics Corporation as the SE555/NE555
- Initially it was called "**The IC Time Machine**"
- It provided circuit designers with a relatively cheap, stable, and user-friendly integrated circuit for both *monostable* and *astable* applications.
- Since this device was first made commercially available, a multitude of novel and unique circuits have been developed
- The past ten years some manufacturers stopped making these timers
- Yet other companies, like NTE (a subdivision of Philips) picked up where some left off

555 Timer Schematic Diagram

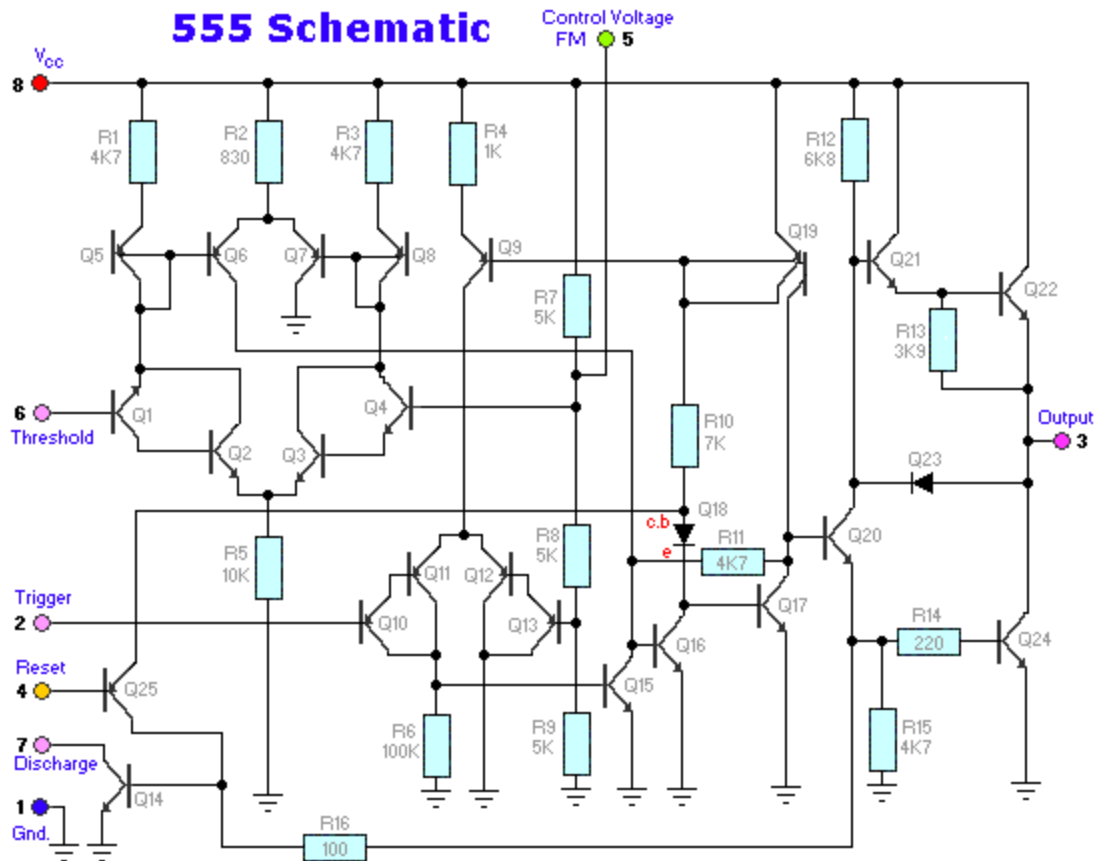

It consists of 23 transistors, 2 diodes, and 16 resistors.

Applications of 555 Timers

- Monostable & Astable Multivibrators
- Waveform generators
- Burglar Alarms
- Measurement, Process & Control Circuits
- Missing pulse detectors
- Traffic light control
- Automatic Battery chargers
- Logic probes
- DC to DC Converters etc.

Simplified Block Diagram representation of 555 Timer

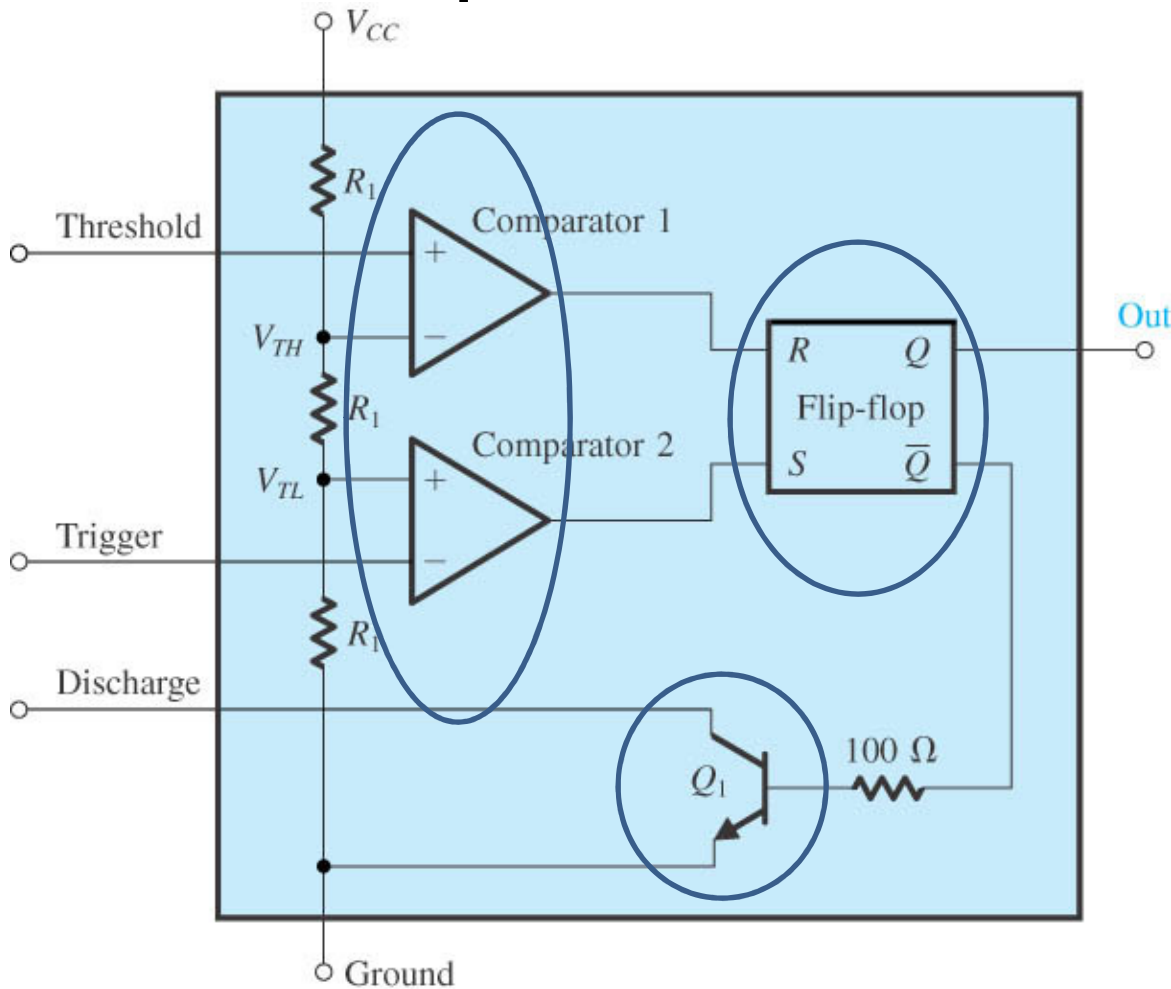

- Consists of two comparators
- Consists of an R-S flip flop
- Consists of Q1 that is operated as a switch

R-S flip Flop Review

<u>R</u>	<u>S</u>	<u>Q</u>	<u>Action</u>
0	0	Last Value	No change
0	1	1	Set
1	0	0	Reset
1	1	?	Indeterminate(forbidden)

555 Timer Pin Configurations

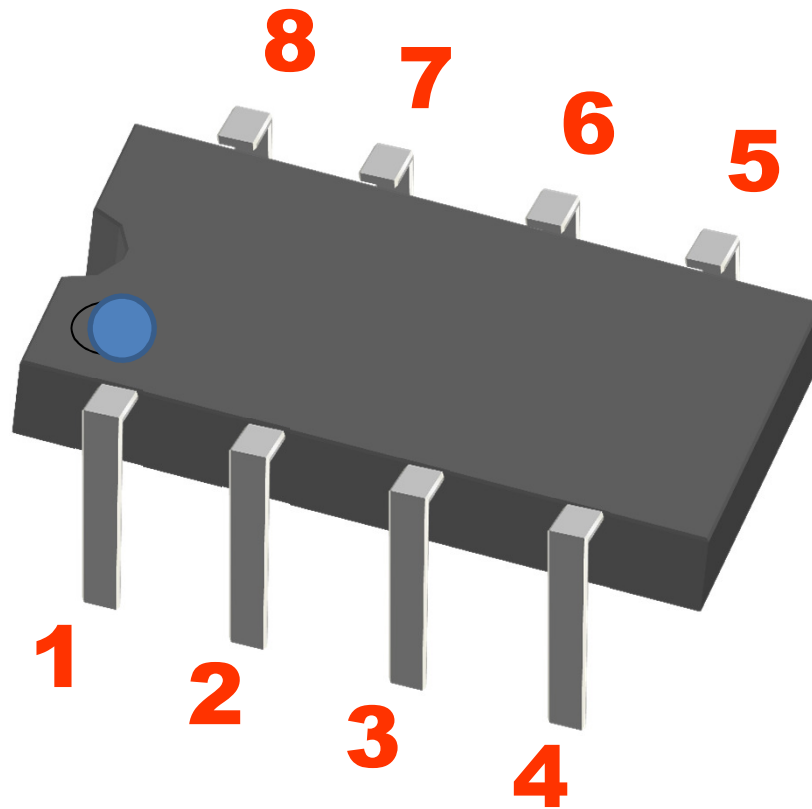

555 Timer Pin Descriptions

- **Pin 1 (Ground):-** All voltages are measured w.r.t. this terminal. This is the most negative supply potential of the device

- **Pin 2 (Trigger Terminal)**

This pin is an inverting input to a lower comparator. This is used to set the flip flop which causes the output to go high

- **Pin 3 (Output Terminal)**

There are 2 ways to connect load to the output terminal.

Pin 3 & Vcc :- Normally On load

Pin 3 & Ground:- Normally off load

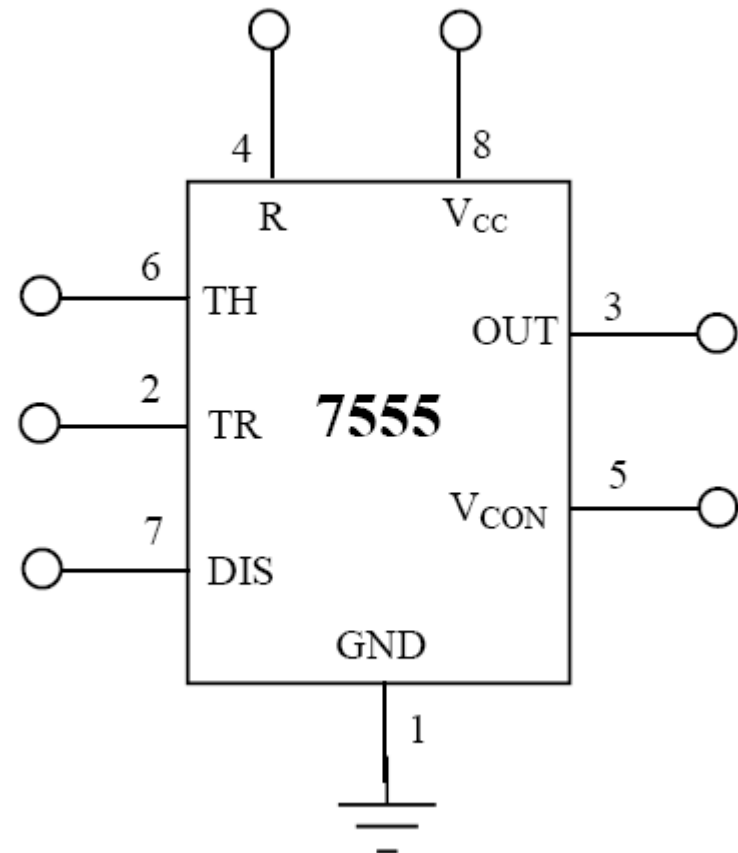

555 Timer Pin Descriptions

•**Pin 4 (Reset):-** To disable or reset the timer a negative pulse is applied to this pin. When this pin isn't used, it's connected to Vcc.

Why ??

•**Pin 5 (Control Voltage)**

The function of terminal is to control the threshold and trigger levels. The external voltage or a pot connected to this pin determines the pulse width of the output waveform. *When not in use, it should be connected to ground through a 0.01uF capacitor to avoid any noise problem.*

•**Pin 6 (Threshold):-** This is an input to the upper comparator. Used to reset the flip-flop which drives the output low.

•**Pin 7 (Discharge)**

-When the npn transistor connected to it is turned "on," the pin is shorted to ground
– The timing capacitor is usually between pin 7 and ground and is discharged when the transistor turns "on"

•**Pin 8 (Supply Voltage):-** A positive supply voltage is applied to this terminal

BASIC TIMING CONCEPTS

- A resistive voltage divider consisting of 3 equal resistors R_1 is employed
- $V_{TH} = 2V_{CC}/3$ for comparator 1.
- Flip Flop is reset whenever threshold goes higher than $2V_{CC}/3$.
- $V_{TL} = V_{CC}/3$
- Flip Flop is set whenever the trigger goes below $V_{CC}/3$.
- In set state output Q is high (approx. equal to V_{CC}) and in reset the output is low

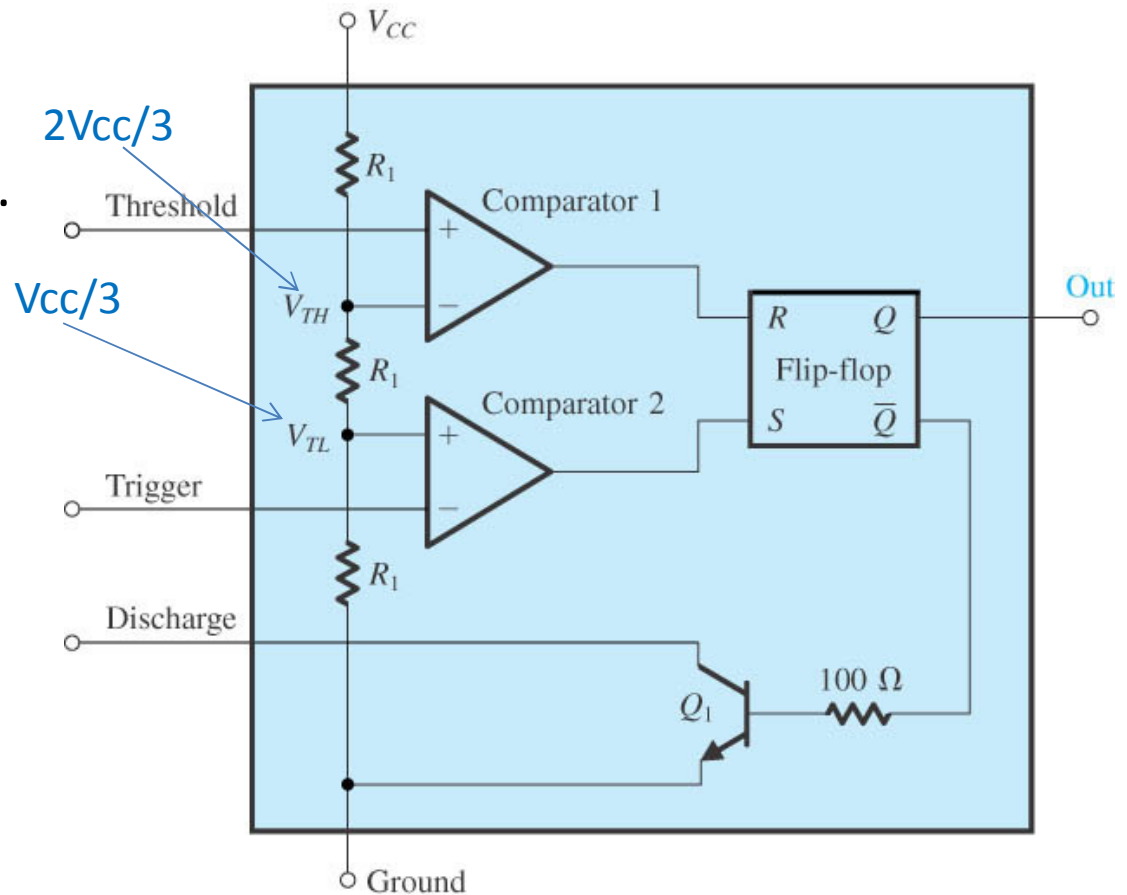

555 timer as a Monostable Multivibrator

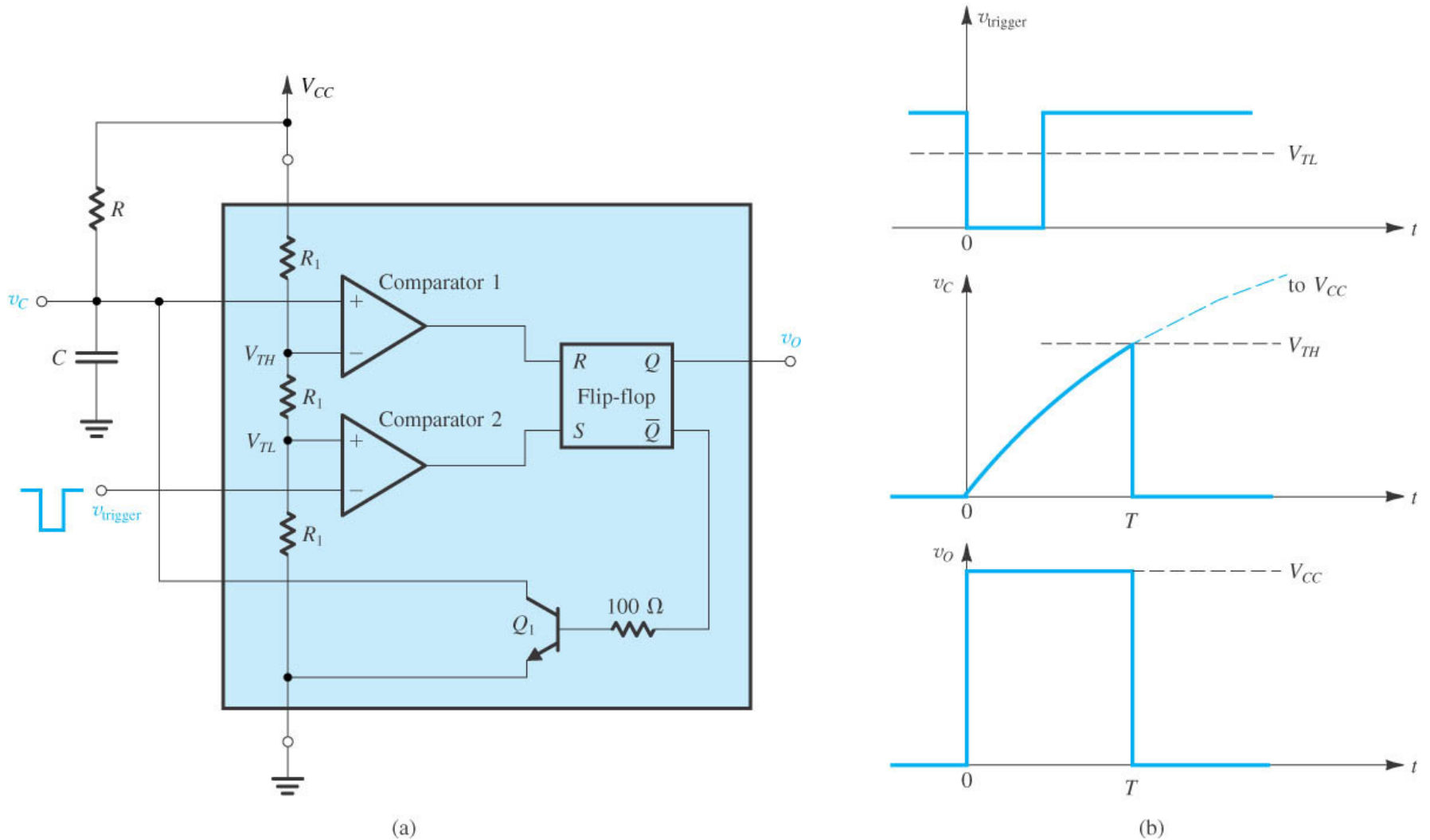
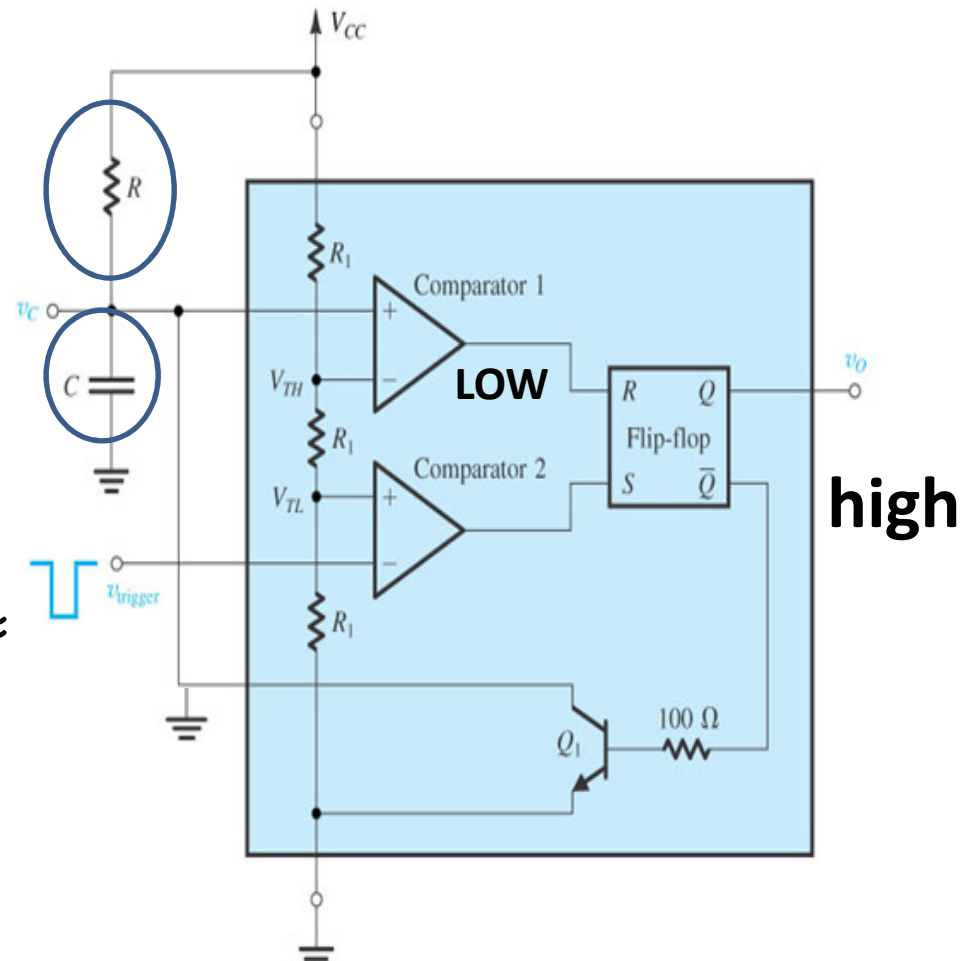

Figure The 555 timer connected to implement a monostable multivibrator. **(b)** Waveforms of the circuit in (a).

Description of the 555 Timer as a Monostable Multivibrator

- Consists of an external resistor R & capacitor C
- In the stable the flip flop will be in reset state, thus \overline{Q} will be high and Q low.
- Transistor Q_1 is driven into saturation
- $V_{CE} \approx 0$ so the capacitor is shorted to ground. i.e. $V_C \approx 0$ and output of comparator 1 is low



Description of the 555 Timer as a Monostable Multivibrator (contd...)

- V_{trigger} is kept high (higher than V_{TL} i.e. $V_{\text{CC}}/3$)
- Output of comparator 2 will also be low
- Flip flop is in reset state so Q will also be low i.e. $V_0 \approx 0$
- To trigger the monostable multivibrator, a negative pulse is applied to the trigger input terminal

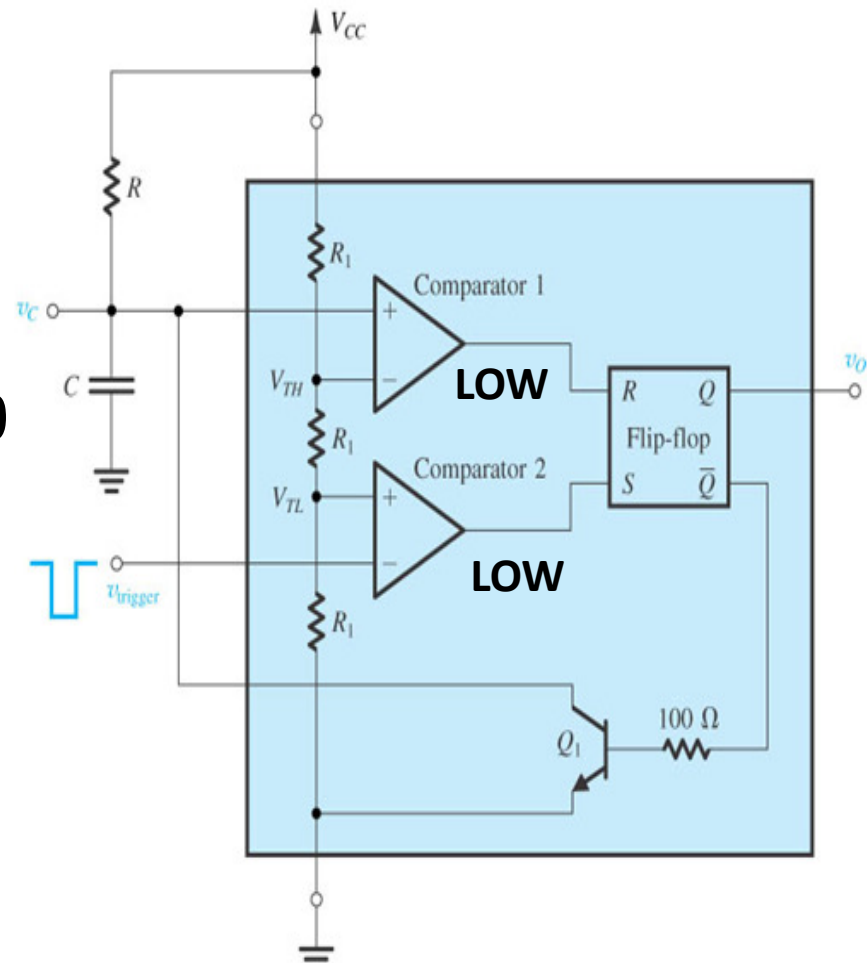

Description of the 555 Timer as a Monostable Multivibrator (contd...)

- As V_{trigger} goes below V_{TL} i.e. $V_{\text{CC}}/3$, the output of comparator 2 goes high thus setting the flip flop. i.e. $Q=1$ $\bar{Q}=0$, so the transistor is cutoff
- V_{trigger} is given for a short time so output of comparator 2 goes low again.
- Still the output is high because $R=0$ and $S=0$ result in Q to be in the previous state.
- Capacitor C now begins to charge through resistor R and V_{C} rises exponentially towards V_{CC} .
- The high voltage at the output is retained as long as $V_{\text{C}} < V_{\text{TH}}$

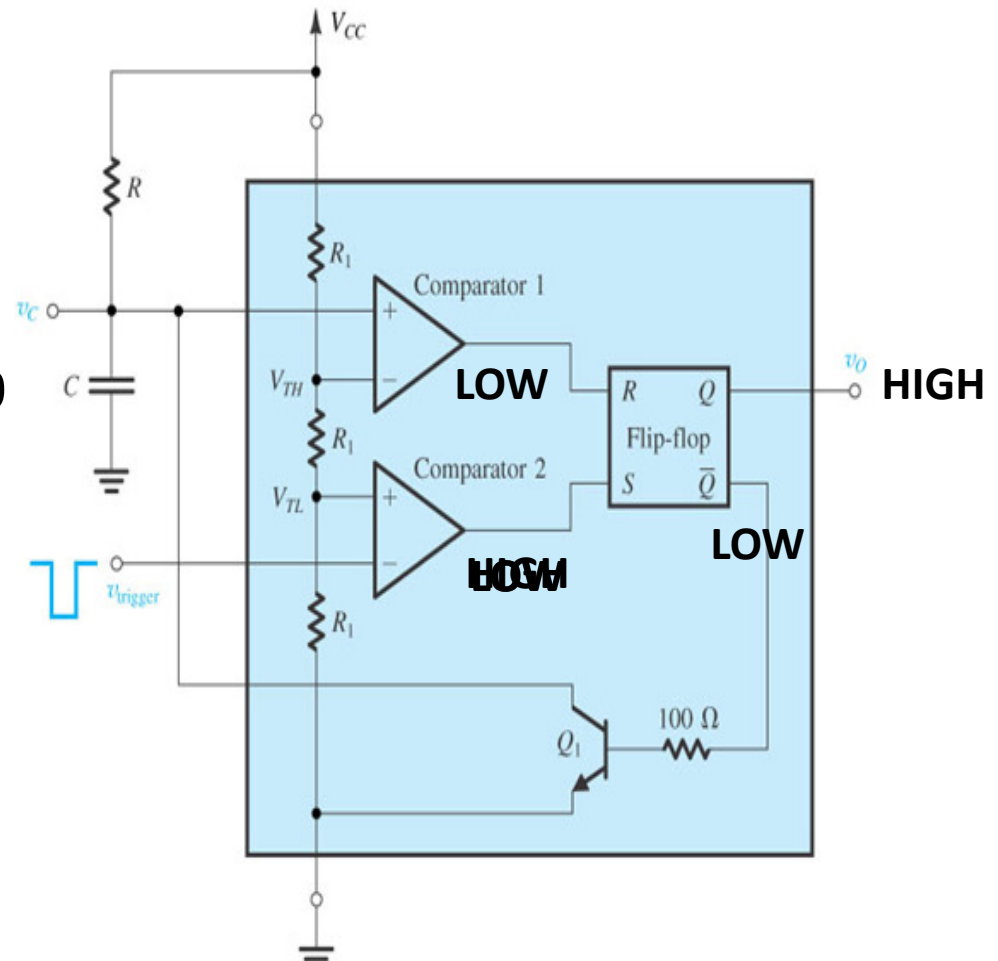

Description of the 555 Timer as a Monostable Multivibrator (contd...)

- Once V_C exceeds V_{TH} , the output of comparator 1 goes high. Now $R=1$ and $S=0$ so $Q=0$
- The monostable multivibrator is now back in its stable state and is ready to receive a new triggering pulse

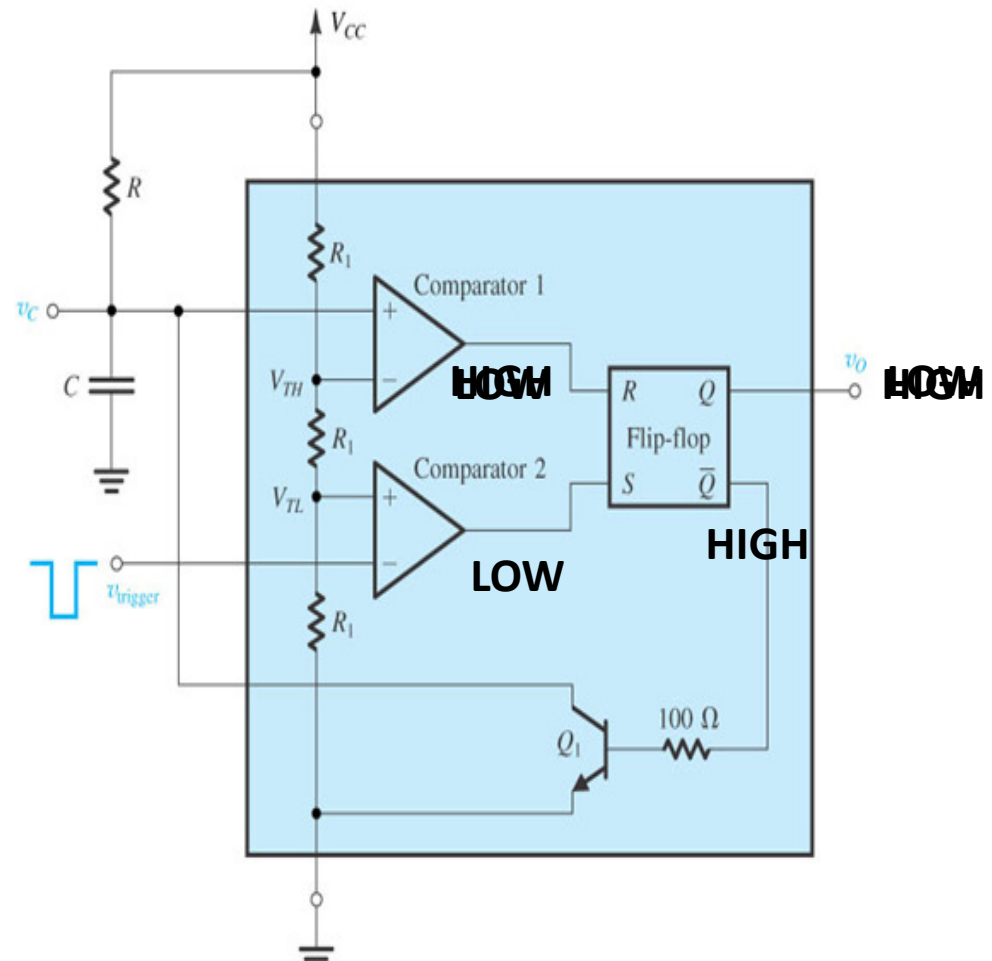

Derivation for the width of the pulse in monostable multivibrator

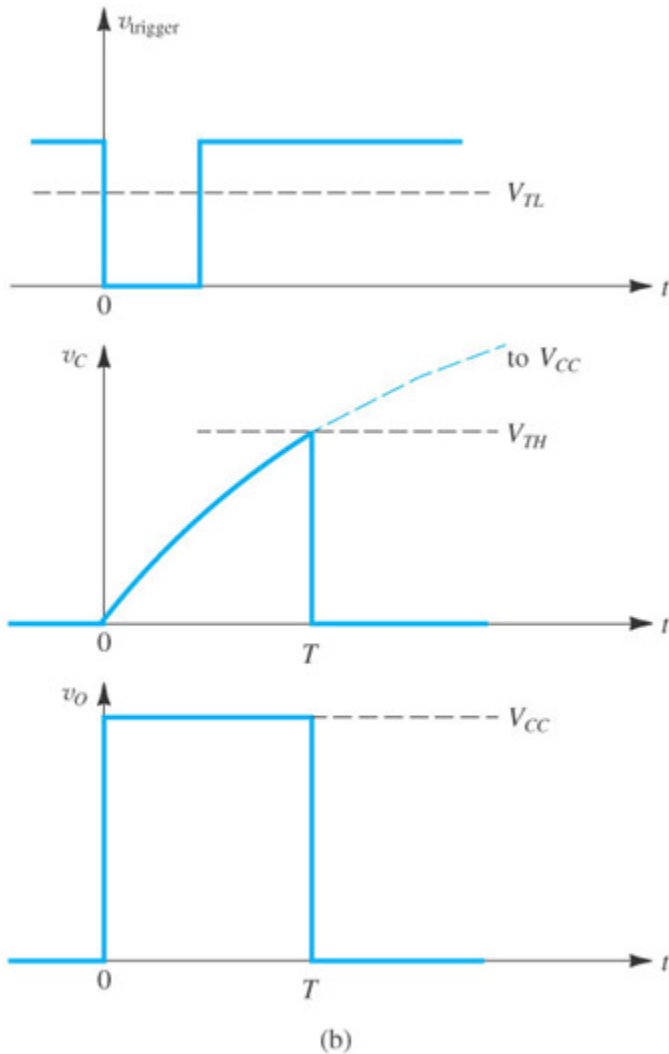

- The width of the pulse , T is the time interval that the monostable multivibrator spends in quasi stable state.
- Denoting the time instant at which the trigger pulse is applied at $t=0$, the voltage across capacitor V_c can be expressed as ,

$$V_c = V_{CC} (1 - e^{-\frac{t}{RC}})$$

- Substituting $V_c = V_{TH} = \frac{2}{3}V_{CC}$ at $t=T$ gives,

$$T = RC \ln 3 = 1.1 RC$$

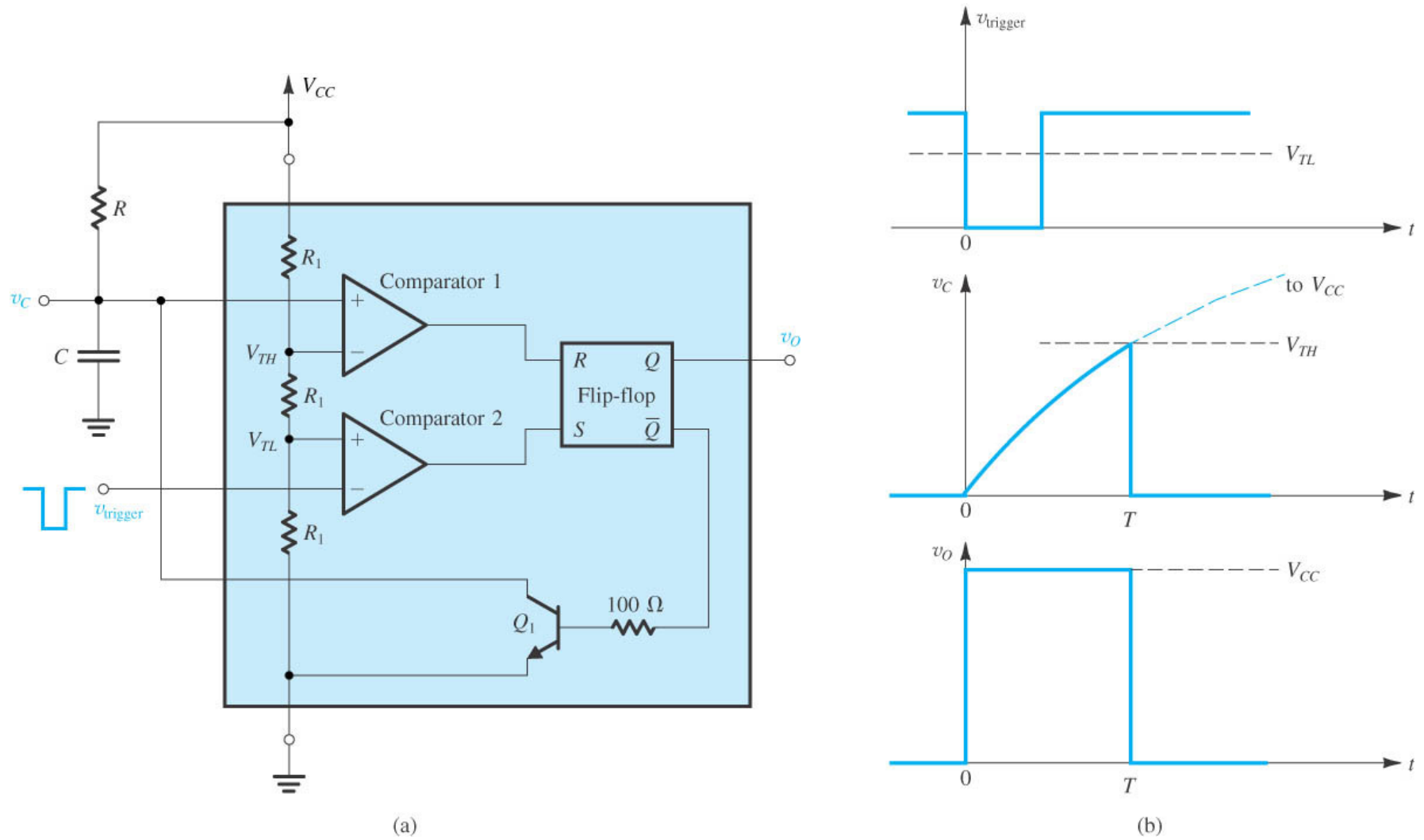
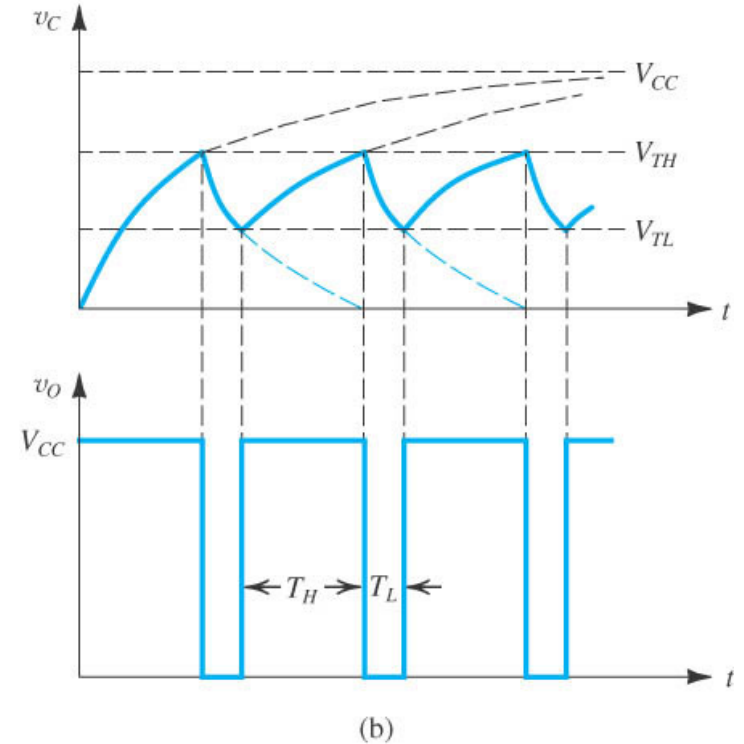
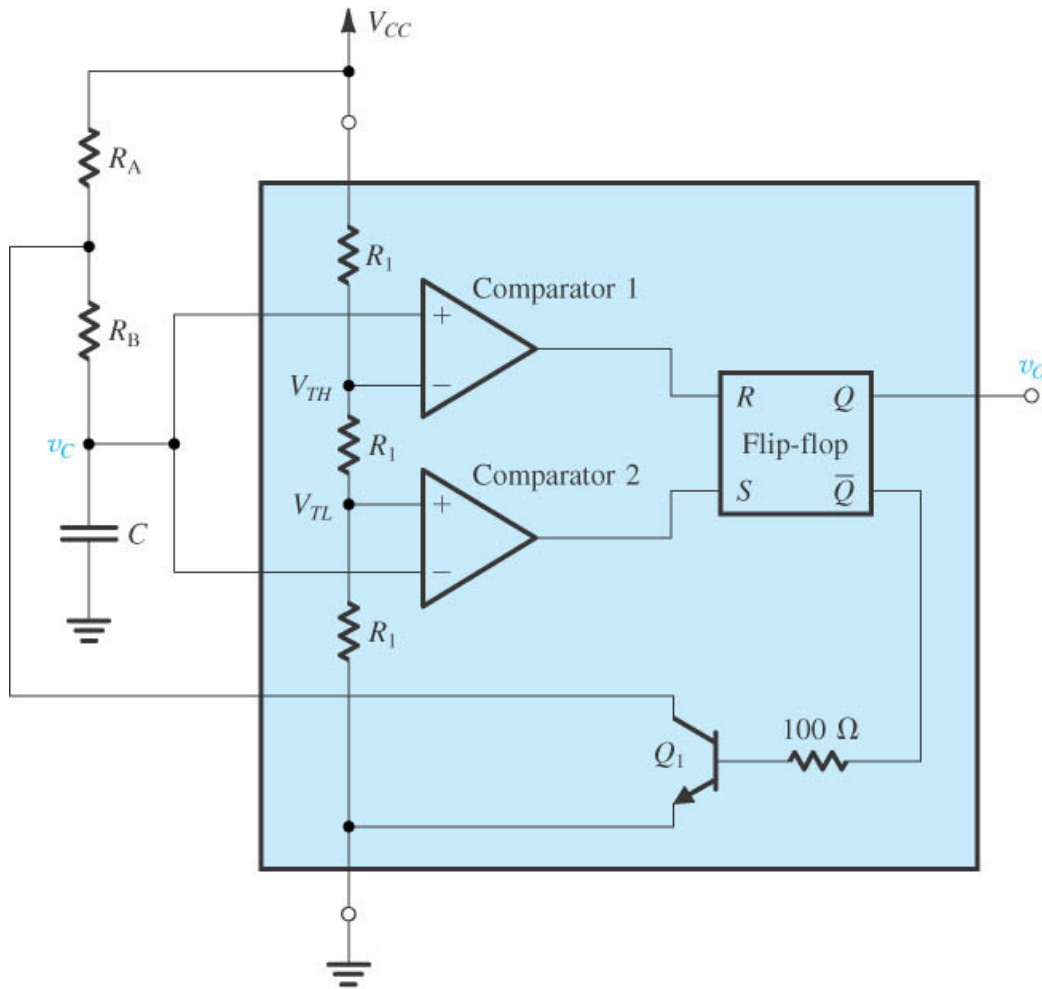

Figure 13.28 (a) The 555 timer connected to implement a monostable multivibrator. (b) Waveforms of the circuit in (a).

555 Timer as an Astable Multivibrator



(a) The 555 timer connected to implement an astable multivibrator. (b) Waveforms of the circuit in (a).