

B.Sc. Applied Physical Sciences (Chemistry) I Year (Industrial Chemistry)

Chemistry- Thermodynamics, Equilibria and Functional Group Organic Chemistry

Section B Organic Chemistry-2

Unit 6

Alcohols, Phenols, Ether, aldehydes and Ketones

(e) Oppenauer's oxidation: Alcohols can also be oxidized by heating it with aluminium isopropoxide in the presence of acetone. This reaction is called Oppenauer's oxidation.

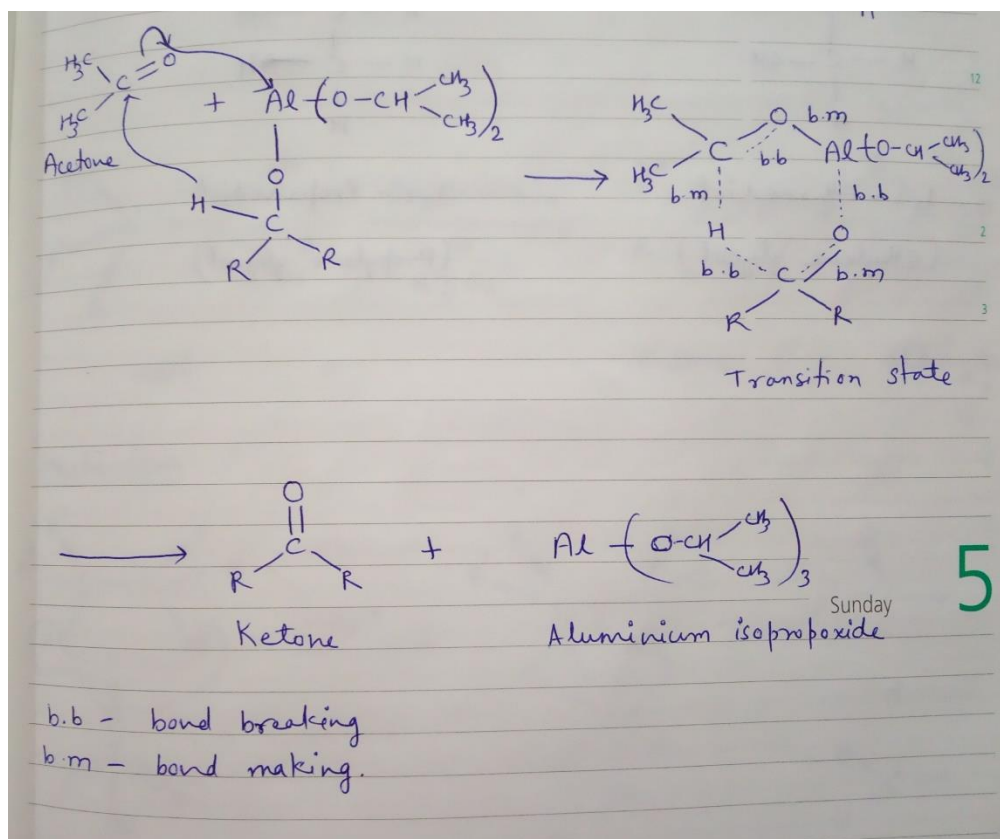
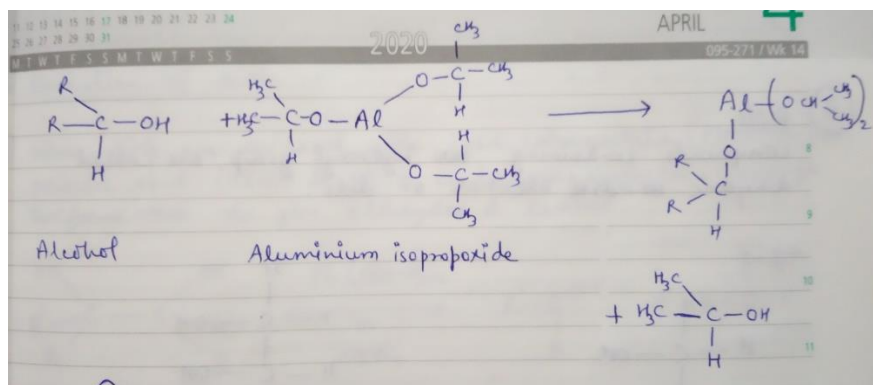

(B) Diols

Compounds containing two hydroxyl group are called dihydric alcohols or diols.

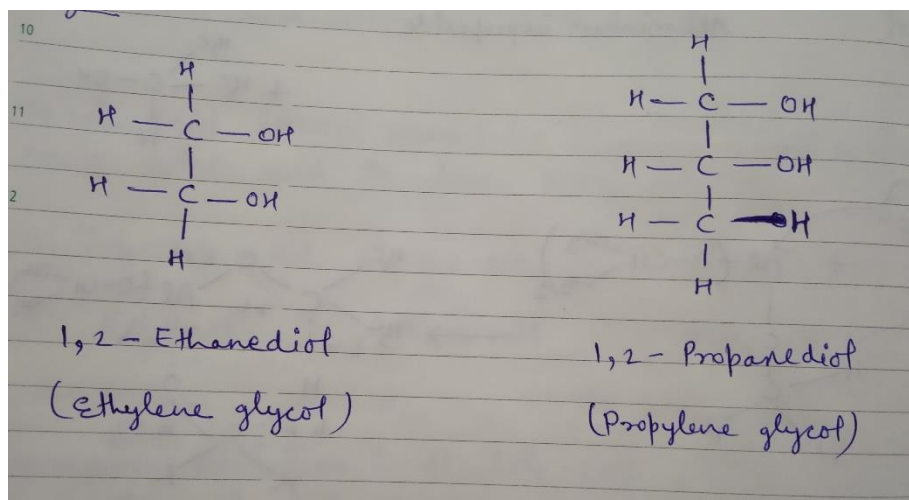

Oxidation of diols

- 1) When diols are oxidised with lead tetra-acetate $[Pb(OAc)_4]$ or periodic acid (HIO_4) it undergoes oxidative cleavage to form aldehyde and ketone.

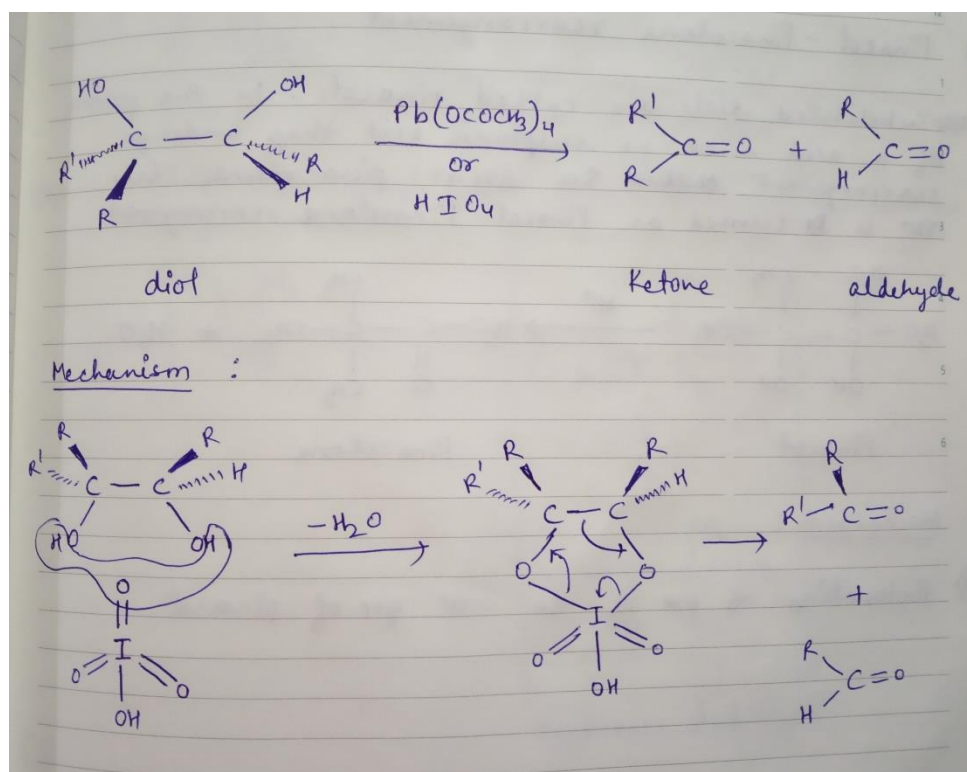

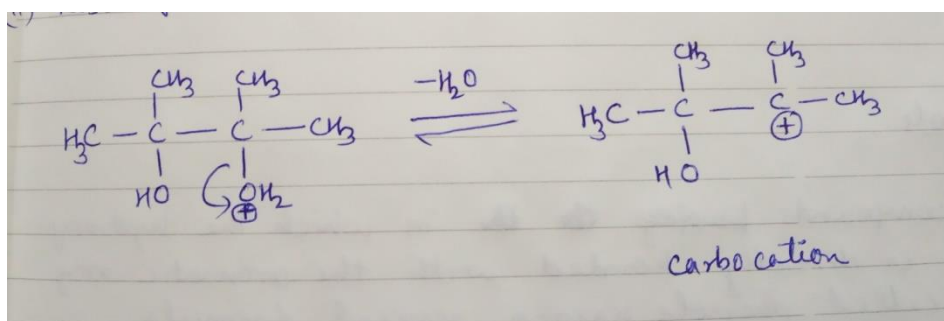

Step 3: 1,2-shift of methyl group occurs to form a resonance stabilized carbocation.

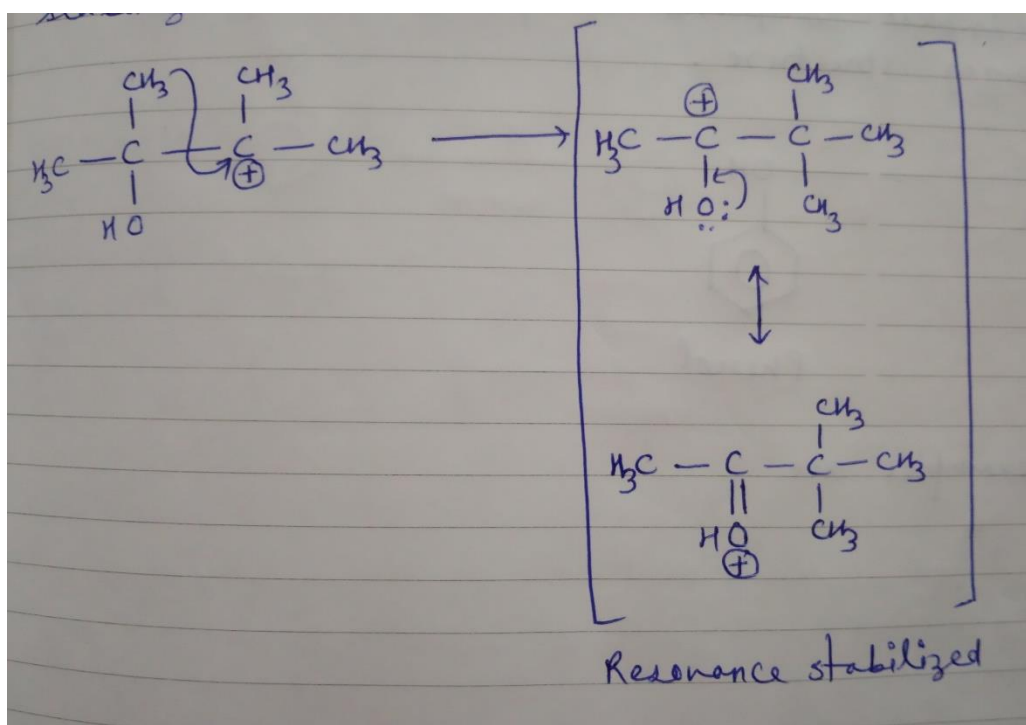

Step 4: Loss of proton gives pinacolone.

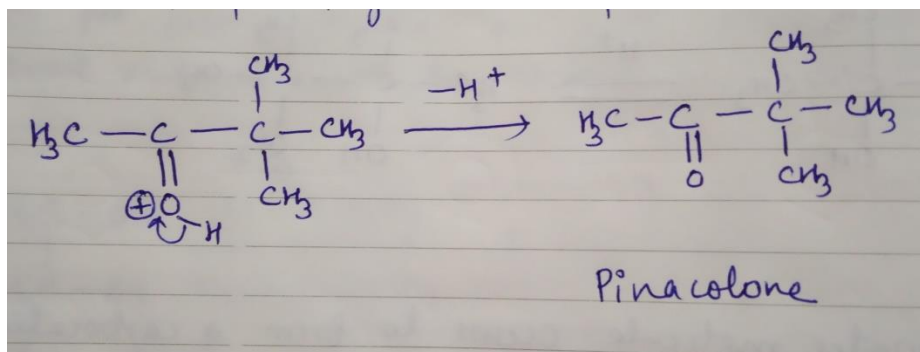

(C) Phenols

The compounds in which the hydroxyl group is attached directly with the aromatic ring are called phenols. They have general formula Ar – OH where, Ar is for Aryl group. The simplest one is phenol. For examples:

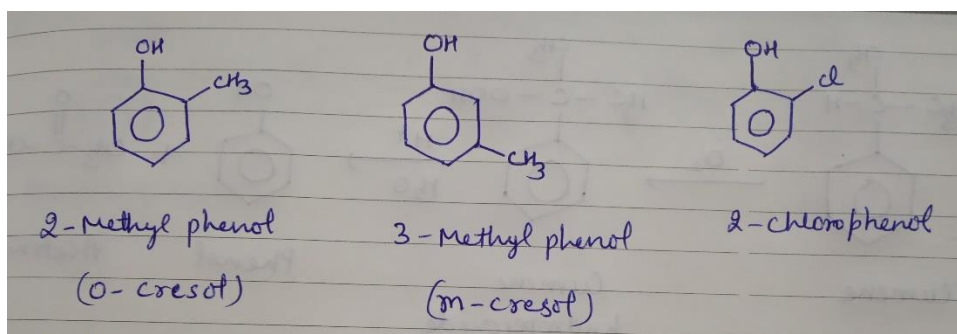
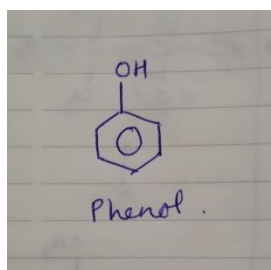

Methods of preparation of Phenols:

- (1) From Cumene: Cumene is prepared from propylene and benzene by Friedel Crafts reaction.

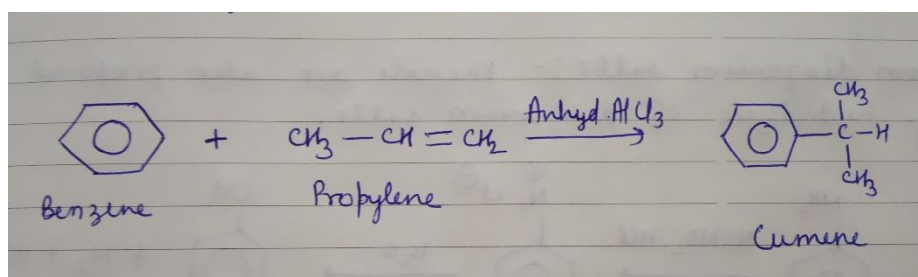

This cumene is oxidised in air (O_2) to give Cumene hydroperoxide which on treating with dilute sulphuric acid forms phenol and acetone. This method is very useful on commercial scale.

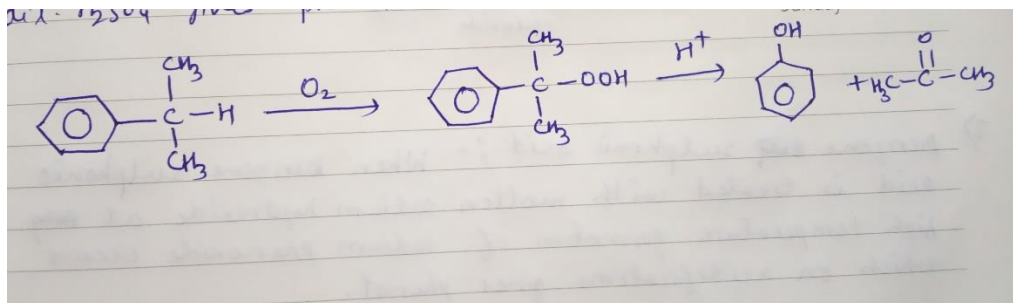

(2) From diazonium salts: Phenols are also prepared by the hydrolysis of diazonium salts.

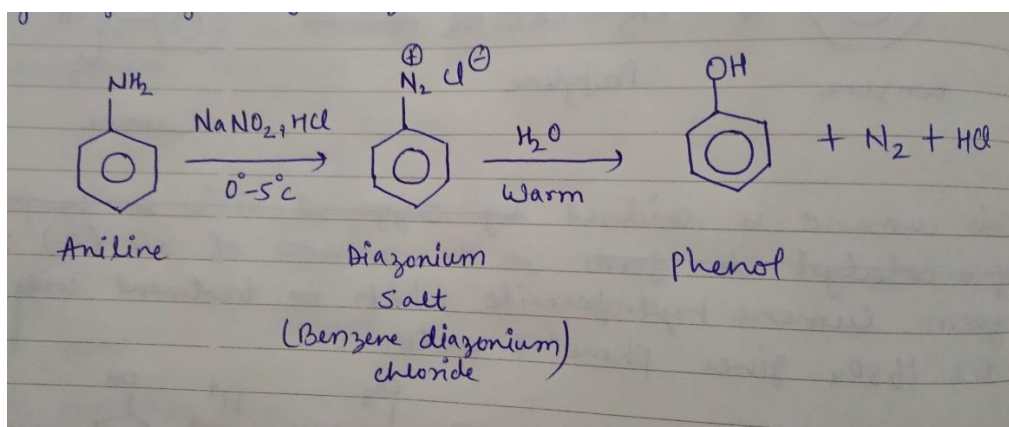

(3) From Benzene sulphonic acid: When Benzene sulphonic acid is treated with sodium hydroxide at high temperature it forms sodium phenoxide which on acidification with dilute sulphuric acid gives phenol.